

## Trouble Shooting

Problem	Solution
Valve won't stop dripping	a) Check float adjustment. Ensure float moves freely.
	b) Disassemble valve and check for sand or scale in valve rubber
	c) Turn valve rubber over and re-assemble. See below.
	d) Check for excessive water system pressure.
Low Water Flow	a) Check that valve inlet is not plugged or supply hose is not kinked.
	b) Check system pressure from supply hose by installing a tee and pressure gauge in front of the valve to check pressure drop when valve is open. A severe pressure drop indicates a restriction or undersized supply system.
	c) Check that shut off valves are fully open.

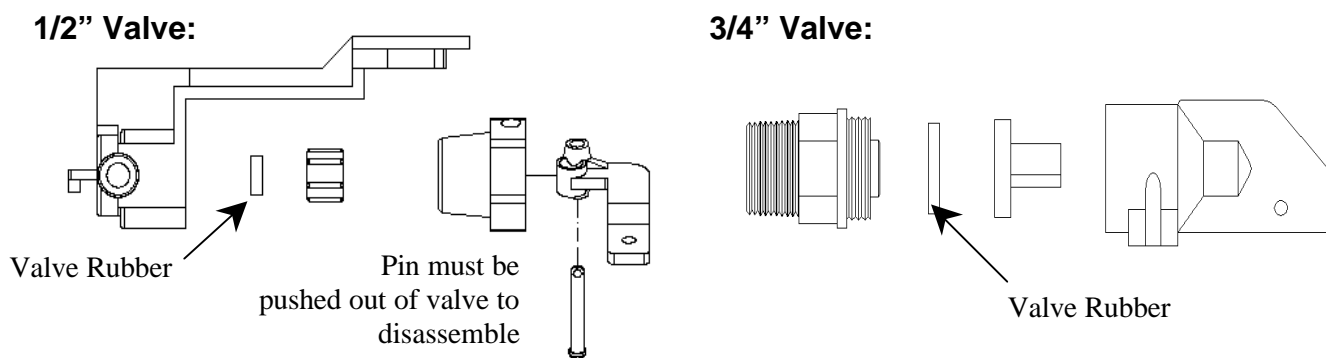

## Ritchie Warranty

Effective May 2005

Ritchie Industries, Inc. warrants its products to be free of defective materials and workmanship. Defective part(s) will be repaired or replaced at the option of Ritchie Industries. **This warranty specifically excludes all labor and shipping charges.**

This warranty does not apply to any appearance items, to any product whose exterior has been damaged or defaced, to any product subjected to misuse, abnormal service or handling, and to any products altered or repaired with other than original equipment or manufacturer's parts.

All warranty claims must be processed through an Authorized Ritchie Dealer/Distributor. **Proof of purchase is required.** The period of warranty begins at original date of purchase as follows:

### Poly Units

#### Base, top and ball closures

10 year limited against manufacturing defect. 100% first five years, then declining 20% per year for the remaining five years.

### Stainless Steel Units

#### Stainless trough and stainless valve chamber frame:

Ten years against manufacturing defect or corrosion. 100% all ten years.

#### Casing and cover:

10 year limited against manufacturing defect. 100% first year, then declining 10% per year for the remaining nine years.

### Component Parts

#### All component parts, such as floats, valves, heating elements:

One year from the date of purchase against manufacturing defect, 100%.

### Hydrants

#### All component parts:

One year from the date of purchase against manufacturing defect, 100%.